

FC SERIES

The FC Series Collector from Scientific Dust Collectors is a totally self-contained, heavy-duty cartridge collector that comes fully-equipped and ready to use for welding smoke, fume of light dust applications. Cartridge changes are made ease with a large hinged door that is fast, safe and clean. No special tools are required using our patented Pedal Actuated Cartridge Release System. The FC is supplied with an AMCA rated backwardly inclined fan for maximum efficiency and quiet operation. The accumulated dust drops into a pull-out dust tray for easy handling.

STANDARD FEATURES

- 12 gauge steel housing with reinforced construction
- Zinc oxide primer on all surfaces with an exterior finish of industrial enamel
- Integral control panel with solid state pulse timer control cleaning system, disconnect switch, pressure differential gauge and blower motor starter
- One full set of high efficiency, spun bond cartridge filters

Model	A	B	C
FC-4	47"	61"	101.5"
FC-8	47"	74"	101.5"
FC-12	47"	110"	101.5"

Larger models available.

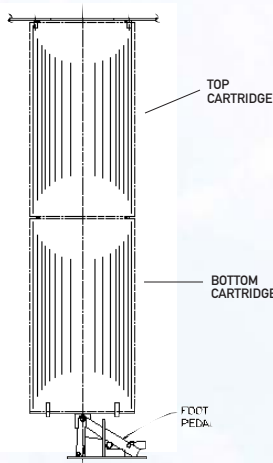

Quick release/engage foot pedal makes cartridge changeout easy.

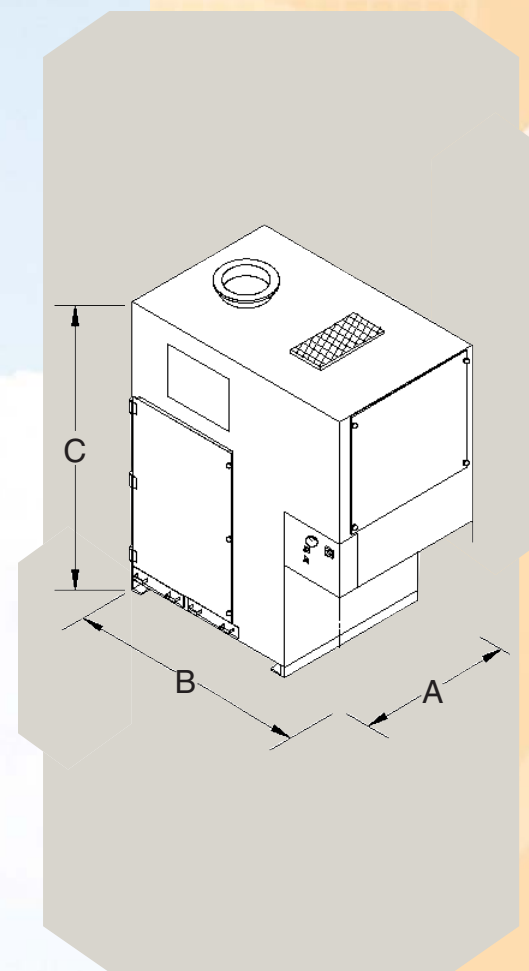

SCIENTIFIC DUST COLLECTORS

4101 W. 126th Street + Alsip, IL 60803 USA
 ph 708.597.7090 + fx 708.597.0313

www.scientificdustcollectors.com
 A Venturedyne Ltd. Company

BUL #801
 05/06